

Nidec

SHIMPO RK-WHISPER

Potter's Wheel Instruction Manual



Thank you for your purchase of the SHIMPO RK-WHISPER Potter's wheel. This manual is provided for you to enjoy throwing clay safely, describing how to use the SHIMPO RK-WHISPER and giving several warnings for safe operation. Please read this manual before you start using the wheel and keep it near the wheel for your reference.

NIDEC-SHIMPO CORPORATION

● Features and Benefits

The Whisper Series offers the power, resilience and quietness that Shimpo wheels are known for. Features of the RK Whisper include

- Heavy-duty steel construction assures long service life.
- Brushless DC motor direct drive system ensures powerful, essentially noiseless operation.
- Unique closed loop micro- controller maintains required speed under heavy load.
- Fixed foot pedal with hand lever offer flexibility in speed adjustment.
- Clockwise and counter-clockwise wheelhead rotation.
- Two year warranty.

● Inspection/Standard Accessories

If upon delivery shipping damage is detected, do not operate the wheel. Notify the shipping carrier immediately for damage claim instructions. Refer to product nameplate and record serial number for future reference.

Items included with the RK-Whisper are:

- Instruction manual.
- T-wrench (for tightening wheelhead).
- Allen wrench for attaching foot pedal.
- Spanner for adjusting feet.



- Foot pedal with hand lever and grip knob.



- Two-piece splashpan.

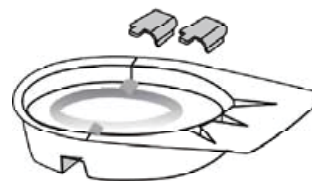

yellow splashpan

● Important Safety Precautions

This machine is built specifically for use as a potter's wheel.
Use for purposes other than pottery may put you at risk of danger or harm

- Do not use your wheel with any voltage other than that specified.
- Do not plug power cord into an extension cord (plug directly into an electrical wall outlet). Do not pull on the power cord to unplug; pull off at plug.
- Do not overload the wheelhead with more than the recommended weight of clay. Do not force the wheel to stop as this may damage your wheel.
- Set up the potter's wheel on a level surface. The top right foot is adjustable and will aid you to level the wheel.
- Remove the metal cover only when adjusting the pedal stiffness. Refer all electrical repairs to a qualified electrical technician.

After operating, before cleaning or inspection:

1. Turn ON/OFF switch to OFF
2. Unplug wheel from power source

● Set-Up

The following steps should be followed BEFORE operating the wheel

1. Remove wheel from shipping box.

2. Place wheel on a firm and stable work surface.

3. Foot pedal and splashpan are shipped disassembled.
Remove them from their packing material.

4. Install pedal.

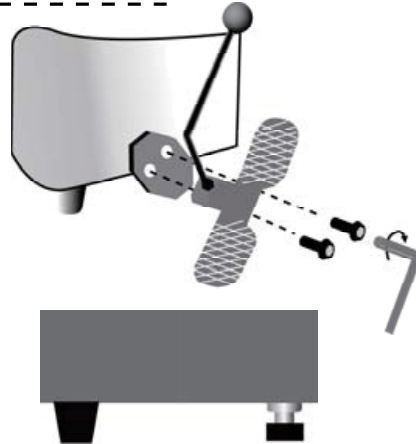

5. Level the wheel.

6 Attach the Two-Piece Splashpan to the wheel, seating it under the flange of the bearing holder (under the wheelhead)

yellow pan

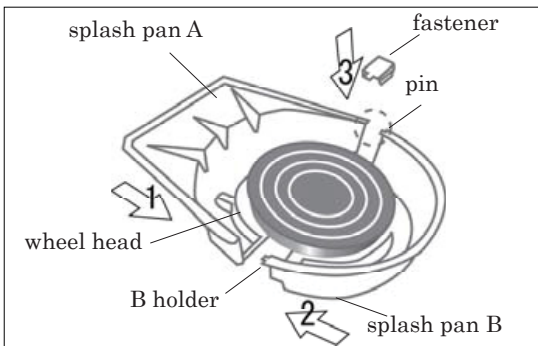

white pan (located under the wheelhead).

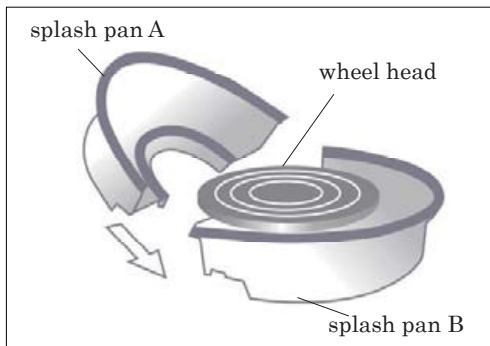

● Description of parts

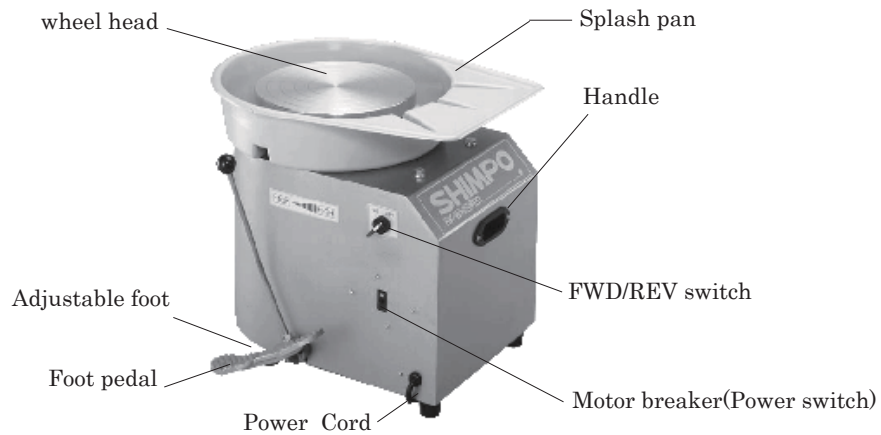

● Operation

1. Plug in rmlly.

2. Turn on the power switch.

3. Turn FWD/REV switch in required direction of rotation. FWD - clock wise, REV - counter clock wise.

4. Depress the speed pedal so that the wheel head will turn.

5. Press pedal forward to increase speed or backward to decrease speed. Press fully back to stop the wheel.

6. Change direction of rotation with the FWD/REV switch.

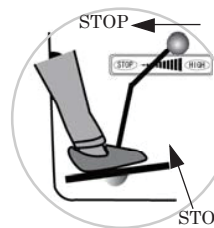
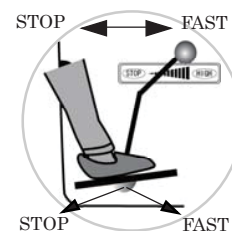

7. DO NOT change rotation direction while motor is running. Do so only after wheelhead has come to a complete stop.

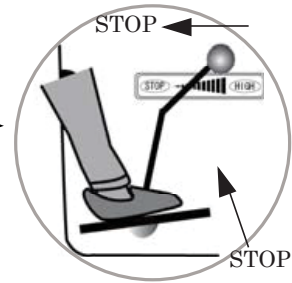

8. At "0" rpm the wheelhead can be turned freely for use as a banding wheel.



● Adjust the stiffness

Pedal might get stiff or loose after long year usage.

In this case, please adjust the stiffness by following procedures.

- ① Turn off the power and unplug the cord.
- ② Remove the legs and cover with the provided wrench.



- ③ Adjust the stiffness of the pedal by tightening the nut in the pedal shaft with the provided wrench.
Fix the cover and legs after adjustment.

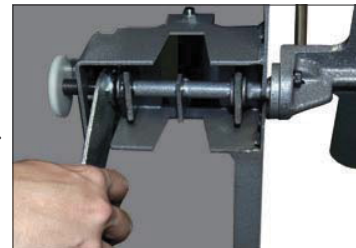

※ Do not touch the other parts.
It might cause defects.

● Maintenance and Safety Precautions

- Turn ON/OFF switch to OFF and unplug your wheel from the power source before cleaning or inspection.
- Never hose down the machine. Clean off the potter's wheel with a damp cloth. Drain your splashpan regularly to avoid a build up of excessive water and clay. Detach the splashpan after each use and clean out thoroughly.
- Touching switches or plugs with wet hands may result in electrical shock.
- Your wheel comes with rubber handles provided for covering the handle openings. Promptly replace any loose or missing rubber handles. Do not insert your fingers or any objects in through these openings.
- Do not tamper with the electrical circuit and controller of your wheel. You may be at risk of getting an electrical shock. Your potter's wheel is a precision instrument and it is advised that you refer operation or performance complaints to a Shimpo-referred, qualified technician.
- Use good judgement and caution when in use around children. Adult supervision must be provided when using around children.
- Take off metal accessories such as rings and watches before handling.
- Do not pick up the wheel by the wheelhead. You may bend the shaft. Lift using only the handles.
- Unplug your wheel from power source if you will not be using it for an extended period of time.

● Specifications

Model: SHIMPO RK-WHISPER

Motor: 400W AC115V AC.60Hz

Drive System: Direct drive DC brushless motor with electric speed control

Wheel head speed: 60Hz 0~250rpm

Speed control: Fixed foot pedal with lever.

Wheel head direction: clock wise/counter clock wise

Wheel head: Light alloy casting, diameter 12" drilled for bat pins

Dimensions: 20"(width) × 21" (Length) × 20" (Height)

Ship Weight: 110 lbs

● Warranty

● LIMITED EXPRESS WARRANTY

Shimpo warrants, to the original purchaser of new products only, that this product shall be free from defects in workmanship and materials under normal use and proper maintenance for two years from the date of original purchase. This warranty shall not be effective if the product has been subject to overload, misuse, negligence, or accident, or if the product has been repaired or altered outside of Shimpo's authorized control in any respect which in Shimpo's judgment, adversely affects its condition or operation.

● DISCLAIMER OF ALL OTHER WARRANTIES

The foregoing warranty constitutes the SOLE AND EXCLUSIVE WARRANTY and Shimpo hereby disclaims all other warranties, expressed, statutory or implied, applicable to the product, including, but not limited to, all implied warranties of merchantability and fitness.

● LIMITATION OF REMEDY

Buyer must have Shimpo's authorization before returning the product, properly repackaged, freight prepaid to Shimpo to obtain warranty service.

Under this warranty Shimpo's SOLE OBLIGATION SHALL BE TO REPAIR OR REPLACE the defective product or part, at Shimpo's option. Shimpo reserves the right to satisfy warranty obligation in full by reimbursing Buyer for all payments made to Shimpo, whereupon, title shall pass to Shimpo upon acceptance of return goods.

● INDEMNIFICATION & LIMITATION OF DAMAGES

Buyer agrees to indemnify and hold Shimpo harmless from and against all claims and damages, imposed upon or incurred, arising, directly or indirectly, from Buyer's failure to perform or satisfy any of the terms described herein. In no event shall Shimpo be liable for injuries of any nature involving the product, including incidental or consequential damages to person or property, any economic loss or loss of use.

● MERGER CLAUSE

Any statements made by the Seller's representative do not constitute warranties except to the extent that they also appear in writing in this contract.

This writing constitutes the entire and final expression of the parties' agreement.

MANUFACTURED BY
NIDEC-SHIMPO CORPORATION
175 Wall Street
Glendale Heights, IL 60139

Phone: 1-800-237-7079 Fax: 630-924-0340